

Monitoring Systems



Existing **BBULL FM and EM** installations have been proven to improve production efficiency and reduce customer complaints.

Features

- Fill-level inspection with filler valve correlation using X-ray, Optical, or Vision technologies.
- Broken Bottles Management with filler valve correlation.
- Cap inspection for presence and quality with Capper head analysis.
- Label inspection for presence, position, and correct label with station correlation.
- Intuitive user-interface with data displays and analysis, plus full access to data for external processing.
- Integration with any of BBULL's industry leading rejection systems.
- Automated Quality sampling program.
- 2-stage machine stop (on defined repair station).
- E-Stop recovery to eliminate exposed product between filler and closer.

BBULL FILLER (FM) AND LABELER MONITORING (EM)

quality management systems have been developed, based on our global experience within the food and beverage industry to provide an integrated quality monitoring and inspection solution. Designed to integrate with existing filler, capper and/or labeler, the system monitors and logs production performance, and manages your factory quality program. The system can be configured to your specific requirements with a full range of add-on inspection modules.

Specifications

Max Speed:	120,000c/h; 2000bpm
Max Line Speed:	2.5m/s; 8.2ft/s
Environmental:	5-40C; 41-104F
Container Types:	most types and designs
Electrical Requirements:	110-250vac; 50/60hz
Air Requirements:	see reject device

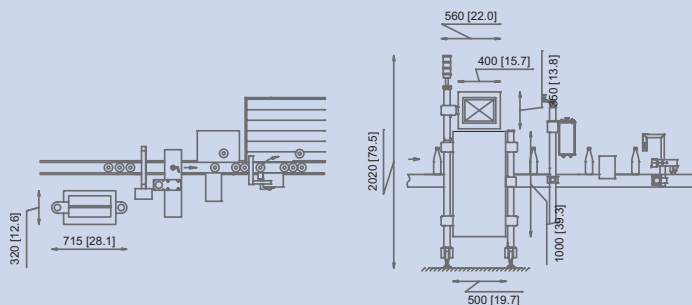

Functionality

The BBULL MONITORING quality management system core is a high quality industrial processing unit and software package. The IMAGE software combines and processes results from a range of monitoring and inspection modules located at key locations on the production lines. The system analysis the results and alerts users to any possible issues. Interfaces are provided for most common production equipment. The correlated data is stored and made available through a compatible ODBC network link.

BBULL[®]
TECHNOLOGY - USA

See videos and more at WWW.BBULLUSA.COM
BBULL USA, Inc. 260 Scarlet Blvd. Oldsmar, FL 34677 USA. Tel: (813) 855-1400 Fax: (813) 855-7460